

CP series impact crushers

CP serisi darbeli kırıcılar



Burçelik CP Series Impact Crushers are used as primary and secondary crushers and they are the leading crusher type at international markets, mainly at West Europe with Burçelik brand.

Features & Benefits

- Used as primary or secondary crusher.
- Suitable for hard-abrasive materials by specially designed hammers and impact plates.
- Settings and maintenance are done easily with the help of hydraulically opened crusher body.
- Protection against overloads.
- High reduction ratio with ideal cubical shape.
- Hinged impact walls.



Burçelik CP Serisi Darbeli Kırıcılar, primer ve sekonder olarak kullanıcıların hizmetine sunulmaktadır. Ağırlıklı olarak Batı Avrupa olmak üzere, en fazla ihraç edilen kırıcılarımızdandır.

Özellikler ve Avantajlar

- Primer ve sekonder olarak kullanılırlar.
- Özel alaşımli çekiçler ve kırma plakaları sayesinde sert ve aşındırıcı malzeme de kırarlar.
- Hidrolik sistem yardımı ile açılan gövde sayesinde ayarlar ve bakım kolay şekilde yapılır.
- Aşırı yük önleme tertibatı vardır.
- Küçültme ve kübik malzeme oranı yüksek kırıcılardır.
- Çarpma kanatları mafsallıdır.



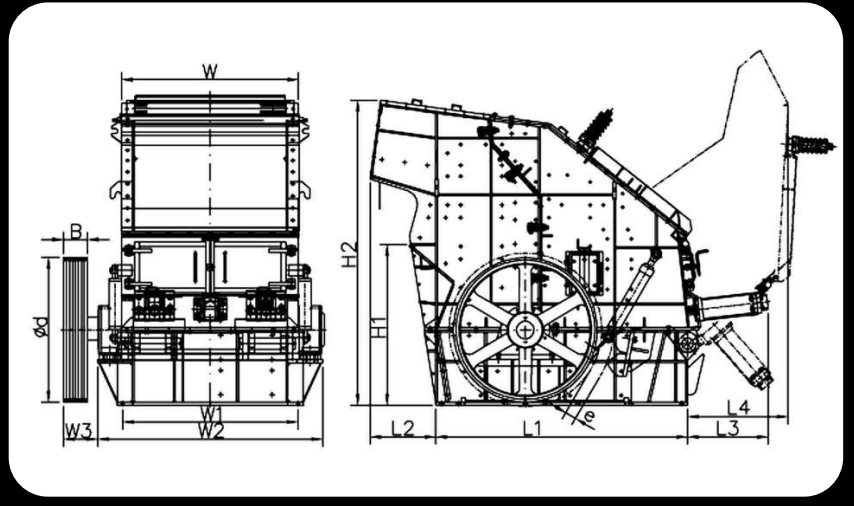
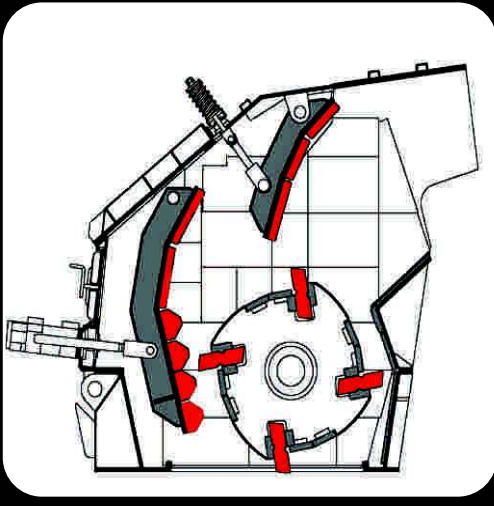

Technical Specifications / Teknik Özellikler

Type Tip	Opening (mm) Giriş Ağızı (mm)	Motor Power (kW) Motor Gücü (kW)	Rotor Speed (rpm) Rotor Hızı (d/d)	Motor Speed (rpm) Motor Hızı (d/d)	Rotor Øx Width (mm) Rotor Øx Genişlik (mm)	Weight (without motor) (kg) Ağırlık (motorsuz) (kg)
CP-110	920-1070	75-160	400-630	1500	1330-1050	15500
CP-130	920-1270	132-250	400-610	1500	1330-1250	18000
CP-168	920-1670	200-315	400-610	1500	1330-1650	20370
CP-150	1200-1510	200-315	400-610	1500	1365-1600	22000
CP-200	1630-2040	320-400	400-500	1500	1565-2000	40000

Capacity / Kapasite

Type Tip	Max Feed Size / Maksimum Parça Büyüklüğü (mm)		Throughput Capacity (t/h) / Kırılan Miktar (t/s)			
	Soft <-----> Hardness Yumuşak <-----> Sertlik	Hardness <-----> Soft Sertlik <-----> Yumuşak	e = 20 mm	e = 30 mm	e = 60 mm	e = 100 mm
CP-110	700	300	50-70	70-110	110-160	160-210
CP-130	800	350	50-90	115-170	160-230	220-310
CP-168	900	350	100-125	160-260	250-360	350-500
CP-150	1000	400		210-280	380-480	450-600
CP-200	1300	500			500-600	600-770

Dimensions / Ana Ölçüler (mm)

Type / Tip	H2	H1	L2	L1	L3	L4	W	W1	W2	W3	B	d
CP-110	2635	1470	500	2195	655	1515	1350	1330	1760	300	212	1260
CP-130	2635	1470	500	2195	655	1515	1550	1530	1960	300	212	1260
CP-168	2635	1470	500	2195	655	1515	1950	1930	2360	400	314	1260
CP-150	2830	1739	521	2305	843	1300	1810	1800	2240	400	314	1260
CP-200	3030	1772	581	2505	843	1300	2310	2300	2740	400	314	1260

Bazalt or Hard Stones / Bazalt veya Sert Taşlar

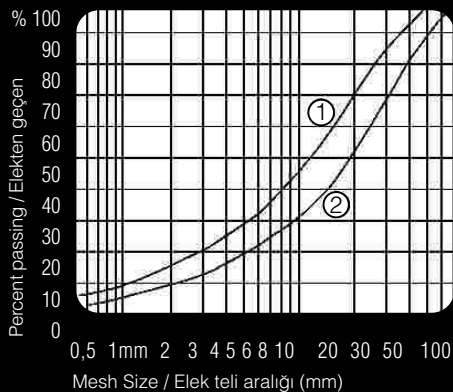

Feed Size : 80-150mm
Besleme : 80-150mm

1. Rotor V = 36.5 m/s
Crushing gap : 20/12mm
Açıklık : 20/12mm

2. Rotor V = 36.5 m/s
Crushing gap : 50/30mm
Açıklık : 50/30mm

Limestone / Kireç Taşı

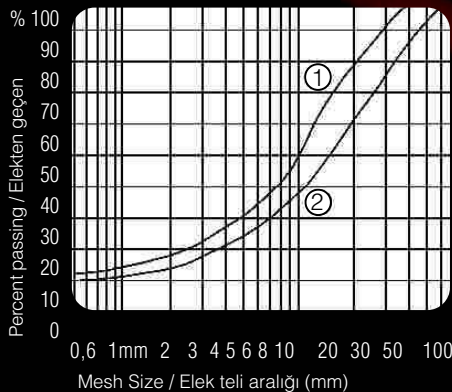

Feed Size : 70-250mm
Besleme : 70-250mm

1. Rotor V = 40 m/s
Crushing gap : 110/40mm
Açıklık : 110/40mm

2. Rotor V = 34 m/s
Crushing gap : 110/40mm
Açıklık : 110/40mm